

**O-C24-XXXXXXXX-X-
Very Low Phase Noise Precision SC-cut
HF OCXO in 20x20 mm Through Hole Package
With DIL14 Compatible Pinout**

Rev. C

Product Data Sheet

Features

- SC-cut crystal
- Ultra Low Phase Noise
- Sine Wave +17 dBm output
- Very small 20x20 mm package
- DIL14 Pinout

Applications

- Telecommunication Systems
- Data Communications
- Radar
- Instrumentation
- High End Synthesizers

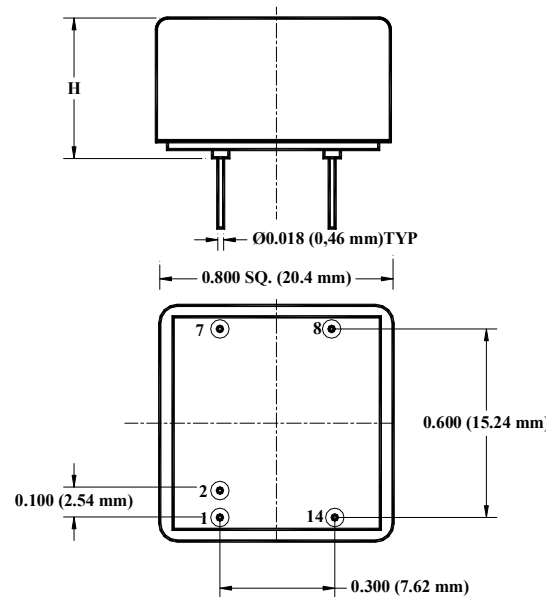

Height, H
0.533±0 (13.5 mm)



**FREQUENCY
CONTROLS, INC.**

357 Beloit Street, Burlington, WI 53105 U.S.A. Phone 262/763-3591 FAX 262/763-2881

Email: nelsales@nelfc.com www.nelfc.com

Parameter	Symb	Condition	Min	Typ	Max	Unit	Note
Absolute Maximum Ratings							
Input Break Down Voltage	Vcc		-0.5		13.0	V	Vcc option F Vcc option 0
Storage temper.	Ts		-55		85	°C	
Control Voltage	Vc		-1		10	V	

Electrical (1)

Frequency	F		80		120	MHz		All parameters for 100.000 MHz	
Frequency stability	$\Delta F/F$	vs. Temp.		± 50		ppb	See table below		
		vs. Supply			2	ppb/5% change			
		Vs. load			2	ppb/5% change			
Aging		per day per first year 10 years		5E-9 5E-7	2.0	ppm	After 30 days of continuous operation		
Allan Deviation		.01s to 1s		5E-11					
SSB Phase Noise at 100.000 MHz	$\mathcal{L}(f)$	10 Hz		-95			dBc/Hz		Grade $\delta L\delta$
		100 Hz			-125				
		1 KHz				-158			
		10 KHz				-170			
		100 KHz				-178			
		10 Hz		-100					Grade $\delta P\delta$
		100 Hz			-130				
		1 KHz			-160				
		10 KHz			-172				
100 KHz			-178						
10 Hz		-105					Grade $\delta U\delta$, Available with slope option $\delta L\delta$		
100 Hz			-135						
1 KHz			-162						
10 KHz			-175						
100 KHz			-180						
Retrace		After 30 minutes		± 20		ppb			
G-sensitivity		worst direction			± 0.5	ppb/G			
Input Voltage	Vcc	12V $\pm 5\%$	11.4	12.0	12.6	V	Option $\delta F\delta$		
		5V $\pm 5\%$	4.75	5.0	5.25	V	Option $\delta O\delta$		
Power consumption	P	steady state, 25°C steady state, -40°C start-up		1.2 2.5 3.0	1.5 3.5	W	Still air		
Spectral Purity		Output power	14	17					
		Subharmonics		none					
		Spurious Harmonics			-80 -30			Non-supply related	
Load	50 Ohm (Internally AC-coupled)								
Warm-up time	τ	to 0.1ppm accuracy		3	5	minutes			
Output Waveform	Sine-wave								
Control voltage	Vc		0		10.0	V	Slope option $\delta L\delta$		
			0		4.5	V	Slope option $\delta P\delta$		
Pull range		from nominal F		± 3.0		ppm			
Absolute pull range	APR		± 0.5			ppm			
Deviation slope		Monotonic, posit		0.7		ppm/V	Slope option $\delta L\delta$		
				1.3		ppm/V	Slope option $\delta P\delta$		
Linearity			$\pm 10\%$						
Reference Voltage	Vref			N/A		V	Slope option $\delta L\delta$		
				4.5		V	Slope option $\delta P\delta$		
Setability	Vc0	@25°C, Fnom.	4.0	5.0	6.0	V	Slope option $\delta L\delta$, no bias		
			1.75	2.25	2.75	V	Slope option $\delta P\delta$		
Modulation Bandwidth	Fm	DC			1	KHz	Note 2		



- Note: 1. All parameters, unless otherwise specified, are at nominal conditions, ie: T=25°C, Nominal Vcc & Nominal Load.
 2. Older and stock units may have MBW of 150 Hz Max.

Environmental and Mechanical

Operating temp. range	0 to 70°C Standard, Other options ó see Chart below
Mechanical Shock	Per MIL-STD-202, 30G, 11ms
Thermal Shock	Per MIL-STD-883, Method 1011, Condition A
Vibration	Per MIL-STD-202, 5G to 2000 Hz
Operational vibration	Phase noise under vibration to be verified by the customer
Seal	Per MIL-STD-883, Method 1014, Cond A and Cond C
Soldering Conditions	260°C for 10s Max leads only

Electrical Connections

Pin Out	Pin #1-- Vc ; Pin#2 ó not present; Pin #7 ó GND; Pin #8 ó Output; Pin #14 - Vcc
----------------	---

Creating a Part Number

Q - C 24 - X X X XX XX X - X - Frequency, MHz

OCXO

Conventional Power

Package Code
 24 20x20mm, DIL14
 Compatible

Supply Voltage

Code	Specification
F	12V ±5%
0	5.0V ±5%

Control Voltage

Code	Specification
L	0 to 10 V
P	0 to 4.5 V

Output

Code	Specification
S	Sinewave

Environmental

Code	Specification
L	Contains a level of lead that is in excess of RoHS directive and is not designed for reflow
R	RoHS compliant, not designed for reflow

Phase Noise Grade (see table)

Code	Specification
L	Standard
P	Premium
U	Ultimate

Temperature Stability

Code	Specification
17	1x10 ⁻⁷
58	5x10 ⁻⁸
28	2x10 ⁻⁸
YZ	Yx10 ^{-Z}

Temperature Range

Code	In 5°C steps **
First letter	Lowest temperature from A = -40°C
Second letter	Highest temperature to Z = 85°C
Examples	
IS	0°C to 50°C
GU	-10°C to 60°C
EW	-20°C to 70°C

****Temperature Code Table**

Letter	Temp °C	Letter	Temp °C	Letter	Temp °C	Letter	Temp °C	Letter	Temp °C	Letter	Temp °C
A	-40	F	-15	K	10	P	35	U	60	Z	85
B	-35	G	-10	L	15	Q	40	V	65		
C	-30	H	-5	M	20	R	45	W	70		
D	-25	I	0	N	25	S	50	X	75		
E	-20	J	5	O	30	T	55	Y	80		

Note: Not all combinations are available ó consult factory

